

Mercedes Sprinter 907 5T Full Air Suspension

2 Corner Heavy Duty IntelliRide Control Kit
(Electronically Controlled Air Suspension)

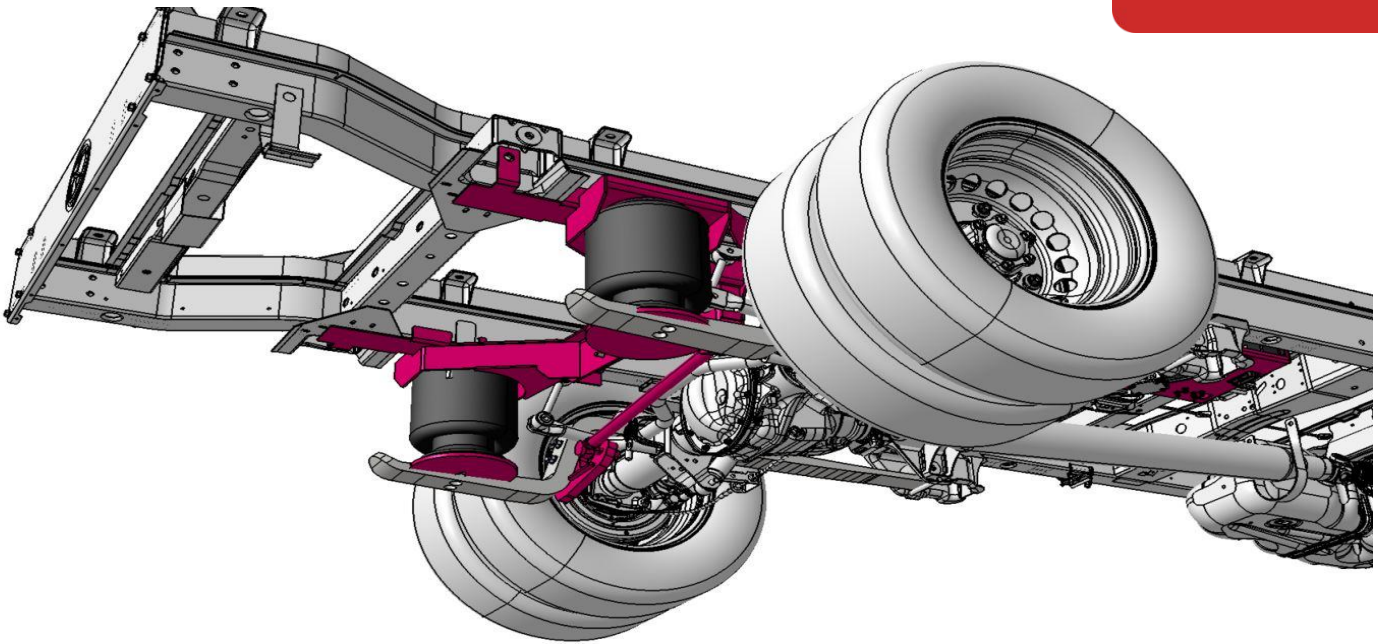

CE - EMC tested and approved

► Preliminary Measurements & Key Features

Preliminary Measurements

- ³ Max Lowering = 75mm
- Preset Lowering will be -65mm from design position
- Max Raise = 30mm
- Preset raised = +20mm from design position

Key Features

- Retains factory rear anti-roll bar
- Custom Koni FSD shock absorbers
- Firestone 1T Style air springs
- 21bar LFK compressor
- One kit for PV and cab chassis 3665mm and 4325mm wheelbase

Benefits of Glide-Rite Air Suspension:

- + Increased comfort and enhanced driving experience
- + Vehicle stability safely improved under all loaded conditions
- + Vehicle less sensitive to high cross winds resulting in reduced sway and improved handling
- + Simple control of the air spring pressure allows height adjustment
- + Optimized geometry (drive line angles)
- + Constant ride height – load independent
- + High-quality components manufactured in Germany, USA and Ireland
- + Easy to install and user friendly systems
- + Reliable: Glide-Rite has more than 25 years of experience in air suspension business
- + Fully tested, approved and homologated by the Original Equipment Manufacturer and TUV



GLIDE RITE®

Mercedes Sprinter 907 5T Full Air Suspension 2 Corner Heavy Duty IntelliRide Control Kit (Electronically Controlled Air Suspension)

▶ System Layout

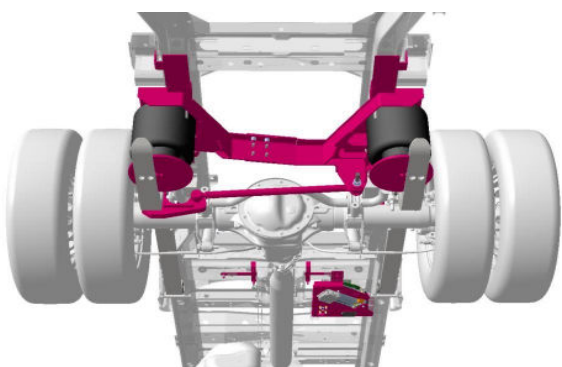
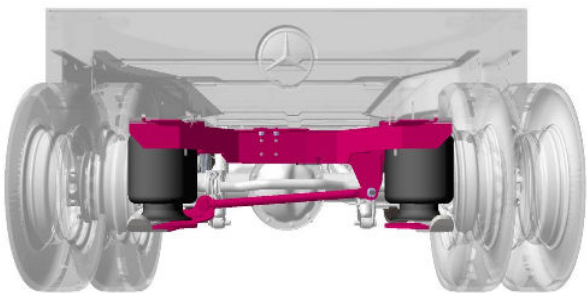
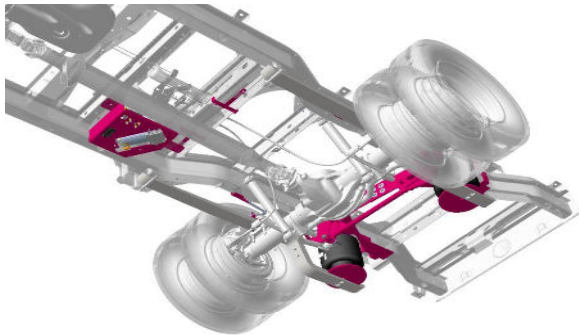
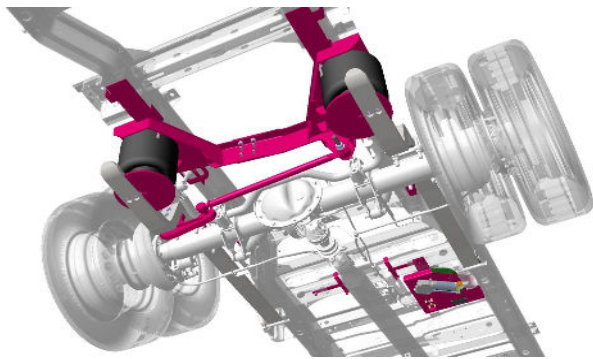

Mercedes Sprinter 907 5T Full Air Suspension

2 Corner Heavy Duty IntelliRide Control Kit (Electronically Controlled Air Suspension)

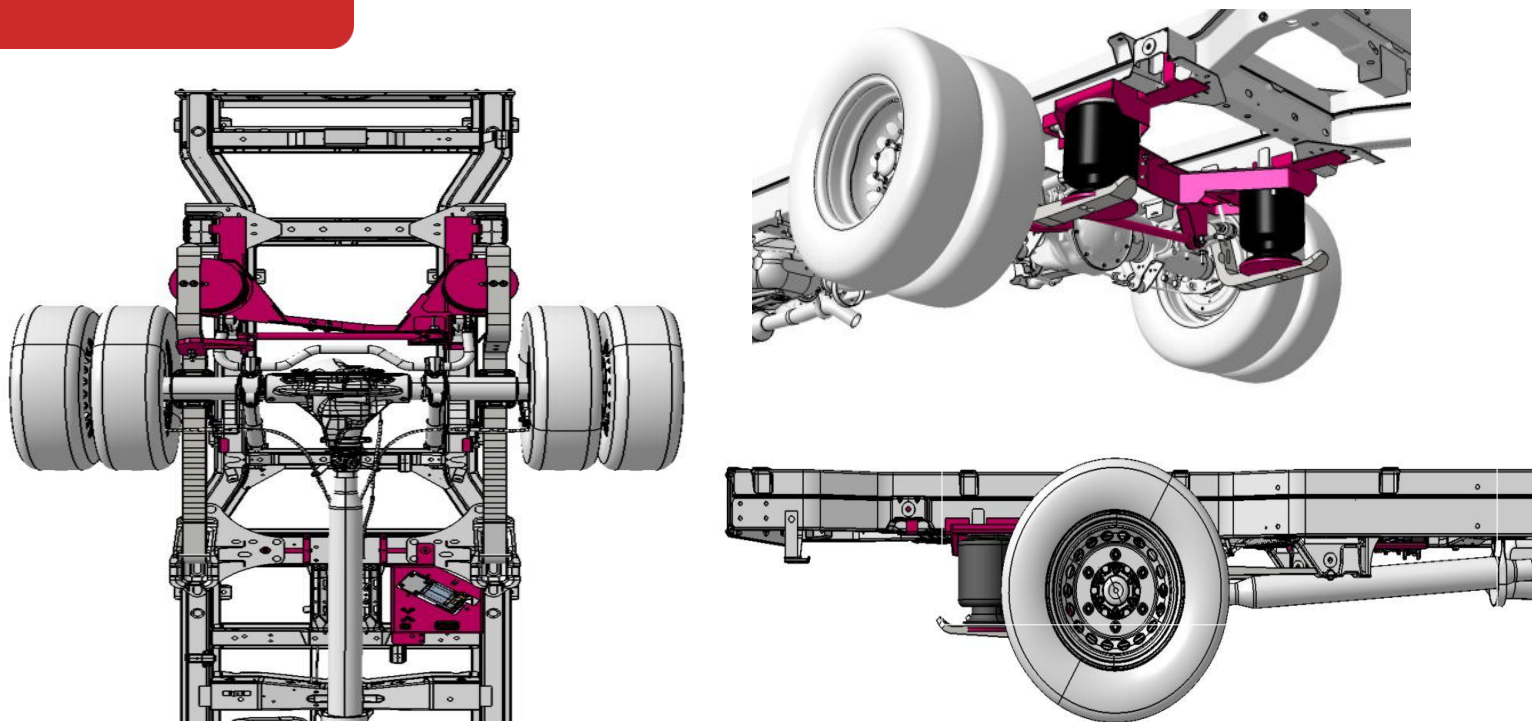

▶ Technical Specifications

Model	Mercedes Sprinter 907/Volkswagen CR35
Year	from 2023 to present day
Kit Number	• GLR-5907
Air spring Style	Firestone, Sleeve Air Spring
Control System	IntelliRide, a user friendly Automatic height control system.
Compressor	AMK 12 V, max. 12 bar
Compressor	AMK 12 V, max. 12 bar

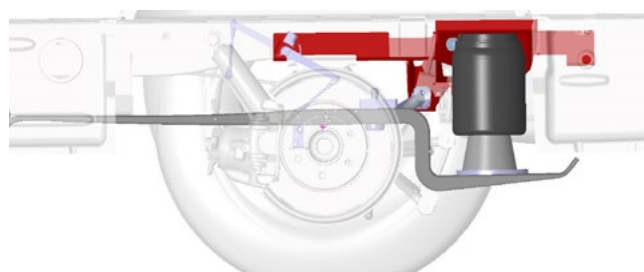

Handheld Controller
The Glide-Rite Handheld

